

IDEAL STEEL HYBRID MODEL 210a

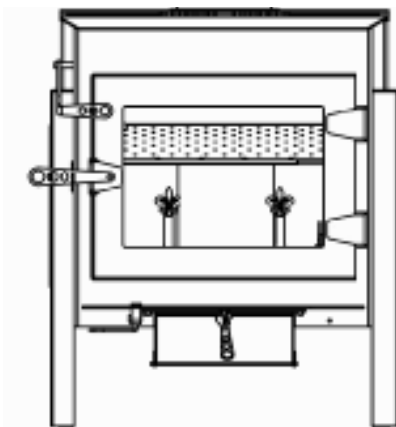

GEAR HEAD STOVES
BY WOODSTOCK SOAPSTONE COMPANY

OWNER'S MANUAL



Tested To UL 1482-2011 7th Edition
Listed By PFS Corporation



Woodstock Soapstone Company, Inc.
66 Airpark Road, West Lebanon, NH 03784
Toll Free 1-800-866-4344 • www.woodstove.com

Rev 06/2020

OUR PROMISE

We are sure you will enjoy your new stove. During the first six months that you own it, test its performance and experience the comfortable warmth of soapstone. If you are not thoroughly delighted with the beauty, quality, and energy efficiency of your stove, you may return it for a full refund, including the cost of return freight. This is the best consumer protection plan in the industry.

EPA APPROVAL

This Manual describes the installation and operation of: the **Model 210a Ideal Steel Hybrid Catalytic Wood Stove**

The **Model 210a Ideal Steel Hybrid Catalytic Wood Stove** meets the U.S. Environmental Protection Agency's May 2020 cordwood emissions standards. Under specific test conditions, this stove has been shown to deliver heat at rates ranging from 9,324 to 43263 BTU/hr., and average emissions of 0.89 grams/hr.

The Steel Hybrid contains a catalytic combustor, which needs periodic inspection and replacement for proper operation. It is against the law to operate this woodstove in a manner inconsistent with the operating instructions in this manual, or if the catalytic element is deactivated or removed.



Tested and Listed by



LISTING TO UL #1482-2011

The **Model 210a Ideal Steel Hybrid Catalytic Wood Stove** has been tested to UL Standard #1482 7th edition 2011 for safety, and is listed by PFS Corporation. UL Standard #1482 is the standard for testing solid fuel heating appliances which is universally recognized by all national building regulatory agencies (SBCC, BOCA, ICBO) and individual states.

Please Note: Tested and Listed for US installations only

LIMITED WARRANTY

Your Woodstock Soapstone Stove will be carefully inspected before shipment. We will replace any part which is defective in material or workmanship, free of cost, for a period of one year from the date of purchase. If a defect is discovered, please contact Woodstock Soapstone Company, Inc. for instructions regarding return or replacement of the defective part.

CATALYTIC COMBUSTOR WARRANTY

The catalytic combustor in your **Ideal Steel Hybrid Catalytic Wood Stove** is fully warranted for three years from the date of purchase against any defect in workmanship or materials that prevent the combustor from functioning when installed and operated properly. The catalytic combustor is additionally warranted for three years from the date of purchase for any deterioration in the stainless steel substrate material. For instructions regarding return or replacement of the catalytic combustor, please contact:

Woodstock Soapstone Company, Inc.
66 Airpark Road
West Lebanon, NH 03768
Phone: 1-800-866-4344 • Web: www.woodstove.com

GEAR HEAD STOVES

Gear Head Stoves is a division of Woodstock Soapstone Co., which is specifically 'geared' to designing and building high efficiency, low emission, and more affordable wood stoves. The first Gear Head Stove, The Ideal Steel Hybrid, was the grand prize winner of the 2013 Wood Stove Design Challenge competition, which judged on efficiency, emissions, affordability, innovation, and user friendliness. The affordable steel construction, hybrid burn technology, and Geared 2U custom designs make each stove uniquely affordable and efficient, as well as uniquely yours.

MODEL 210a
IDEAL STEEL HYBRID CATALYTIC
TABLE OF CONTENTS

WARRANTY INFORMATION / CERTIFICATIONS..... Inside Cover
EPA Certification, UL Listing, Warranty, Catalytic Combustor Warranty

INTRODUCTION
Ideal Steel Hybrid Wood Stove Explained

INSTALLATION..... 1-13
Installation, Location, Chimneys, Fireplace Installation, Clearance Table, Wall Protection, Floor Protection, Setting up Your Stove

OPERATION.....14-18
Seasoning Your Stove, Starting a Fire and Establishing Draft, Engaging the Catalytic Combustor, Reloading & Overnight Burning, Ash Removal, Surface Thermometer, Overfiring, Daily Use, The Fall-Away Handle, Firewood

CATALYTIC COMBUSTOR..... 19-21
How your Combustor Works, Inspection & Cleaning, Replacement, Catalytic Probe Thermometer, Frequently Asked Questions, Catalytic Combustor Warranty Information

MAINTENANCE..... 22-23
Stove, Stone & Glass Cleaning, Gasket Replacement, Routine Checks, End-Of-Season Maintenance, Creosote

TROUBLESHOOTING..... 24-25

SAFETY..... 26-27
Overview, Installation, Smoke & The Chimney, Heat, Ash Removal, Precautions, Emergency Procedures

PARTS LIST & DIAGRAMS..... 28-36

MAINTENANCE LOG & NOTE SHEET.....37

DIMENSION & SPECIFICATIONS..... Back Cover

INTRODUCTION

The Ideal Steel Hybrid Combustion System Explained

The Woodstock Soapstone Company's tradition of building high quality, dependable wood stoves continues in the Ideal Steel Hybrid Wood Stove. This new design combines modern technology to achieve clean and efficient heating performance with rugged reliability and affordable steel construction.

While the Ideal Steel Hybrid shares some time tested features with other members of the Woodstock Soapstone family, it also includes some features that are unique. The Ideal Steel Hybrid has a large glass front that benefits from our proven air-wash design, but unlike our other wood stoves, the glass front is also a large loading door. The door swings open wide for access to a large firebox which can be loaded front-to-back or side-to-side, depending on the length of your wood. Innovative andirons protect the glass and can fold out of the way when the door is opened for loading. The firebox can be lined with thick soapstone panels or firebrick, and the exterior is plate steel in order to make the Ideal Steel Hybrid more affordable.

The Ideal Steel Hybrid has a hybrid combustion system similar to the one that we pioneered in our Progress Hybrid wood stove. The combination of the catalytic combustor and the secondary combustion system gives the operator a wide range of heat output while maintaining a clean and efficient burn. In addition to the Hybrid combustion design, the Ideal Steel Hybrid incorporates new automatic catalyst air to optimize the catalytic combustor's effectiveness.

Hybrid burn technology improves efficiency, lowers emissions, and allows for a wider range of output to meet the heating needs of the operator. Hybrid stoves from Woodstock combine the best attributes of both catalytic combustors and secondary combustion systems. A brief description of each is below, followed by a more detailed explanation.

Catalytic Combustion:

- Burns woodstove exhaust gases starting at 500° F
- Operates best at low to moderate burn rates
- Typically yields long duration burns that are clean and efficient
- Improves stove efficiency by generating heat from burning wood smoke

Secondary Combustion:

- Burns woodstove exhaust gases starting at approximately 1000° F
- Operates best at moderate to high burn rates

- Creates hot firebox for maximum heat output
- Provides a very active fire that is great for viewing

Catalytic combustors are well suited for very long burn cycles. Catalytic combustors have the ability to reduce or eliminate woodstove pollution at low stack temperatures. This means much cleaner, more efficient burns at low firing rates than is possible without a catalyst. The catalytic reaction eliminates harmful combustion byproducts and converts exhaust to water vapor and carbon dioxide. The catalytic combustor burns exhaust gasses and converts them to heat, which is captured inside the stove. This extra heat increases the overall efficiency and output of a catalytic wood stove. The combustor takes full advantage of the energy in wood smoke that would otherwise be lost up the chimney as pollution and wasted energy at low burn rates.

Secondary combustion systems are designed to maximize efficiency and reduce emissions as well, but they operate differently. The secondary combustion system introduces secondary air in the firebox to ignite the volatile gases produced by the burning wood. This reaction requires temperatures over 1000 degrees F to start breaking down the organic compounds in the wood smoke. Secondary combustion systems work best when the stove has high firebox temperatures and secondary combustion air introduced into the high temperature area at the top of the firebox. With secondary combustion the exhaust gases burn at very high temperatures before leaving the firebox, providing an unusual display of secondary flames in the top of the firebox.

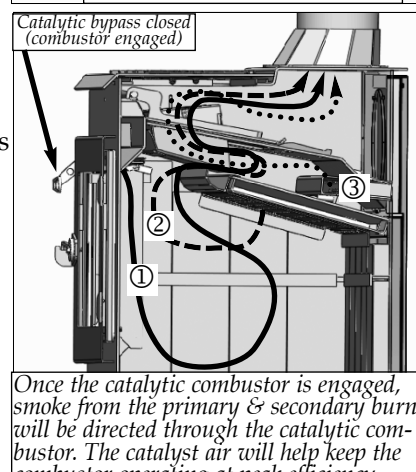
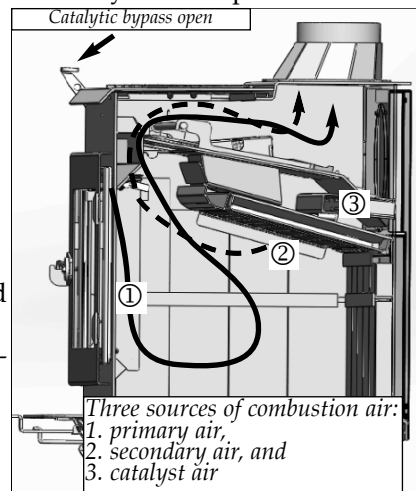

In addition to primary and secondary air, the Ideal Steel Hybrid incorporates a system to introduce air directly to the catalytic combustor as it heats up. When the catalyst is fully engaged a self adjusting, bimetallic coil opens a small damper to allow heated air into the exhaust path just upstream from the combustor. This dedicated "catalyst air" keeps the combustor active and helps control primary and secondary burn rates. As the stove and chimney heat up and draft is increased, more catalyst air is added automatically. This has the effect of stabilizing primary and secondary air and at higher temperatures will actually reduce primary and secondary air. The catalyst air design acts similar to a barometric damper. The catalyst air improves emissions and efficiency at high burn rates, provides overfire protection, and stabilizes the burn rate- automatically.

These systems are not mutually exclusive and have been designed to work together. The Ideal Steel Hybrid is designed to utilize each system depending on the conditions present in the firebox. This makes operating the Ideal Steel Hybrid as simple as possible while providing a clean and efficient burn over a wider range of heat output.

The Ideal Steel Hybrid wood stove. The perfect combination of affordability, innovative combustion technology, and rugged construction.

DIMENSIONS & SPECIFICATIONS

H x W x D (Max. Leg Height)..... 35.5"x29.5"x27.5"
 HxWxD (Min Leg Height)..... 30.5"x29.5"x27.5"
 * Cannot have Ash Pan at the Lowest Leg Height
 Leg Height Adjustment.....5" (in 1" increments)
 2020 EPA Certified (cordwood)..... Yes
 Catalytic Combustor & Secondary Air Standard
 Listed to UL 1482..... Yes
 Flue Exit..... Top or Back
 Flue Size..... 6"
 Flue Height to Center (Max Leg Height)..... 29.5"
 Flue Height to Center (Min. Leg Height)..... 24.5"
 Weight..... 620 lbs.
 Ash Pan..... Optional
 * Cannot have Ash Pan at the Lowest Leg Height
 EPA Emissions Rating..... 0.89 grams/hr

EPA Efficiency..... 82.79% LHV
 EPA Efficiency..... 76.94% HHV
 Area Heated..... up to 2,200 sq. ft.
 Burn Time..... 10-14 hrs.
 Heat Output Range..... 9,324 - 33,263 BTU/hr
 Loading Door..... Front
 Loading Door Opening (HxW)..... 12"x17"
 Back Clearance (no protection)..... 14"
 Side Clearance..... 19"
 Back Clearance (w/Heat Shield Kit)..... 6"
 Bottom Heat Shield..... Standard
 Draft Control..... Manual
 Wood Length (Maximum)..... 22"
 Firebox Size (22"W x 18"D x 12-15" H)..... 3.2 Cubic/ft.
 Window Size (viewable)..... 12"H x 17"W

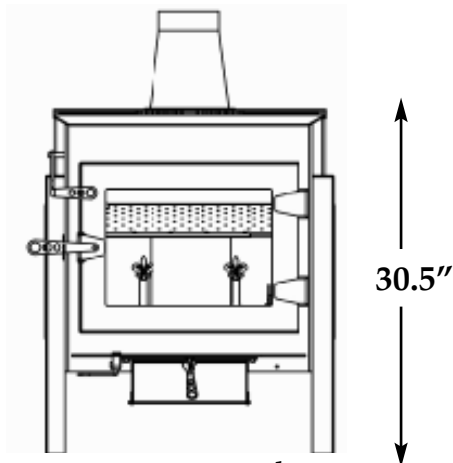
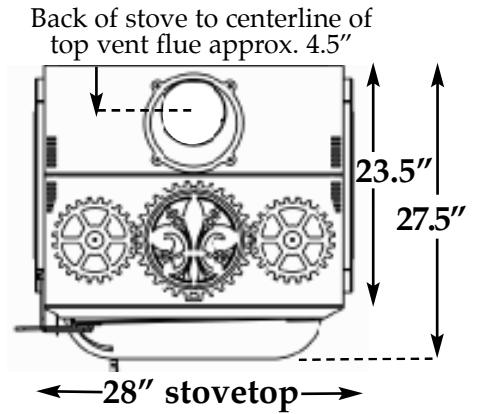
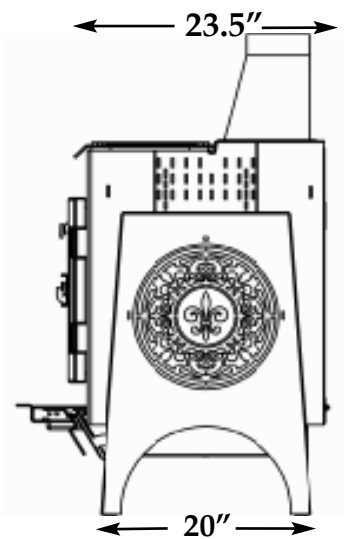
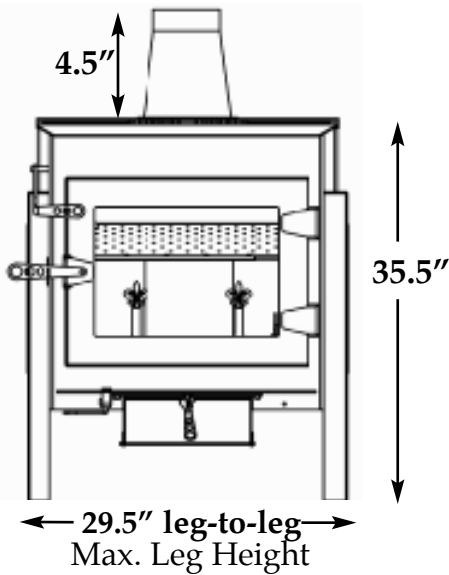

Min. Leg Height
 * Cannot have an Ash Pan at the Lowest Leg Height

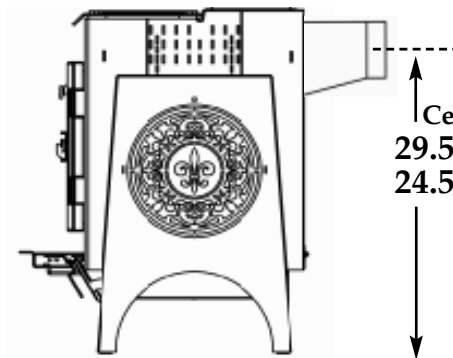

Centerline to rear 6" flue



GEAR HEAD STOVES
BY WOODSTOCK SOAPSTONE COMPANY